

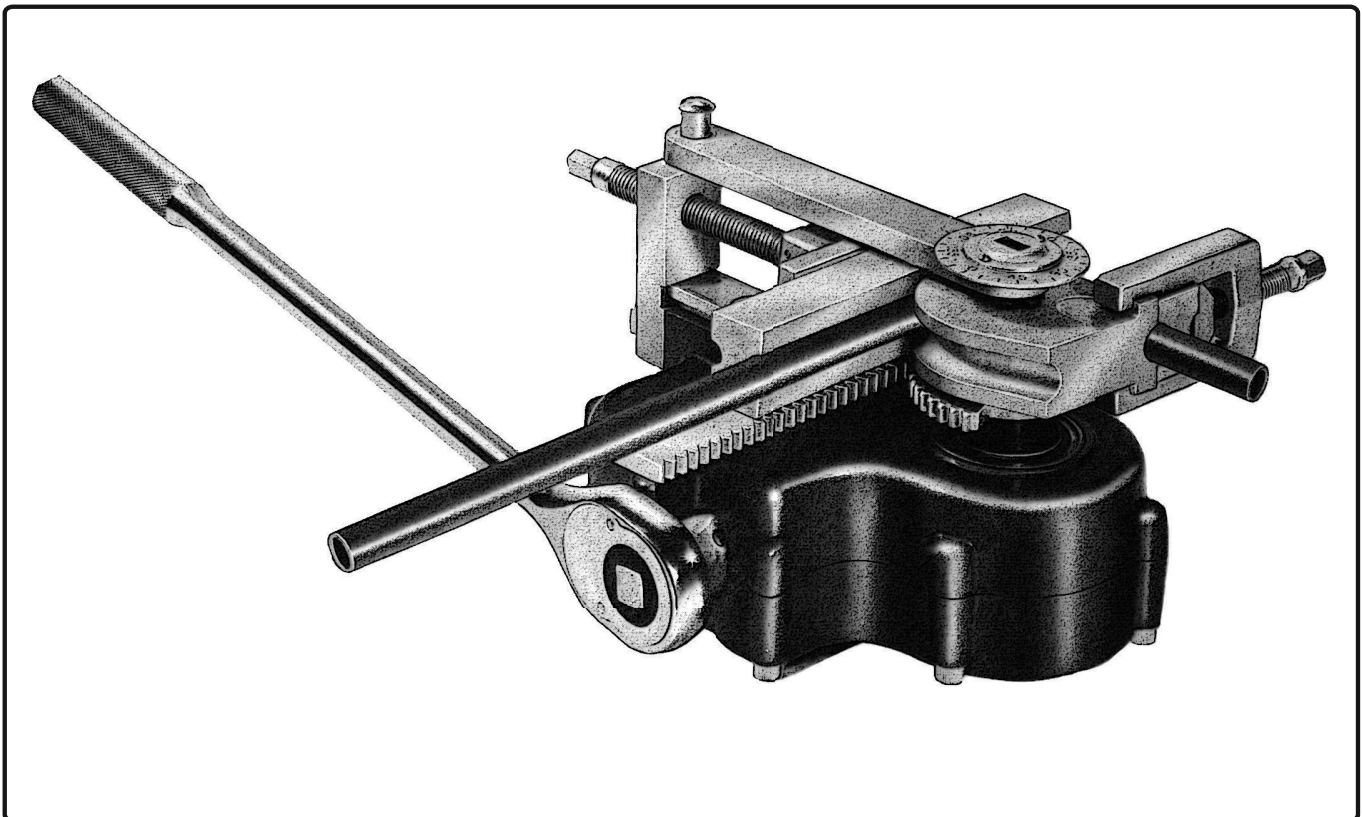

No. 700-F TUBE BENDER

Operation and Service Instructions With Replacement Parts List



⚠ Warning!

Keep body parts away from pinch/bend areas while using.
Ensure tubing is secure in tool before bending.
Always wear approved eye protection.
Broken materials may fly.



Fig. 1 Main Components

| Index No. | Imperial Part No. | Part Name | Index No. | Imperial Part No. | Part Name |
|-----------|-------------------|----------------------------|-----------|-------------------|-----------------------------|
| 1 | 74603 | CARRYING CASE ASSEMBLY | 11 | 74588 | BLOCK (3/8 & 1/2") |
| 2 | | BASIC TUBE BENDER ASSEMBLY | 12 | 74589 | BLOCK (5/8 & 3/4") |
| 3 | 74608 | RATCHET WRENCH | 13 | 74554 | SHAFT (1/4") |
| 4 | 74609 | WRENCH | 14 | 74555 | SHAFT (5/16 - 3/4") |
| 5 | 74591 | YOKE ASSEMBLY | 15 | 74569 | BLOCK GEAR ASSEMBLY (1/4") |
| 6 | 74565 | RACK | 16 | 74572 | BLOCK GEAR ASSEMBLY (5/16") |
| 7 | 74566 | FORM SHOE (1/4 & 5/16") | 17 | 74575 | BLOCK GEAR ASSEMBLY (3/8") |
| 8 | 74567 | FORM SHOE (3/8 & 1/2") | 18 | 74578 | BLOCK GEAR ASSEMBLY (1/2") |
| 9 | 74568 | FORM SHOE (5/8 & 3/4") | 19 | 74581 | BLOCK GEAR ASSEMBLY (5/8") |
| 10 | 74587 | BLOCK (1/4 & 5/16") | 20 | 74584 | BLOCK GEAR ASSEMBLY (3/4") |

SECTION I USE AND MAINTENANCE

1. INTRODUCTION

2. This handbook provides descriptive data, installation, operation and maintenance, and replacement parts list for the Imperial 700-F Tube Bender Kit.

3. Information contained in Section 1 is presented for the purpose of providing personnel, responsible for using and servicing the tube bender, with factory approved data to ensure successful results in the use and repair of the equipment. Section II lists and illustrates replaceable assemblies and subassemblies, and individual parts that can be procured when replacements are required.

4. Each tube bender kit is packaged in a strong steel carrying case which is equipped with brackets and studs placed to hold individual components in an orderly arrangement. The equipment contained in the kit is designed to bend cold drawn, corrosion resistant steel tubing conforming to Specification MIL-T-6845, with outside diameters and wall thickness specified in Table 1.

5. Each form block assembly has a gear sector pinned directly to it, however, a single rack is used with all sizes of form shoes. The drive shaft having upper splines of the larger diameter handles form blocks from 5/16 inch to 3/4 inch inclusive, while the drive shaft with the smaller diameter upper splines handles only the 1/4 inch form blocks.

6. DESCRIPTION AND FUNCTION

7. The Tube Bender Kit will bend corrosion resistant, cold drawn steel tubing, conforming to Specification MIL-T-6845, in sizes and wall thickness listed in Table 1. When operating according to instructions contained herein, bends up to 180° can be made while retaining the original diameter of the tube within 5% at the bend. Bends are not restricted to a single plane. A wide range of compound bends and "S" bends can be handled.

NOTE

Although the tube bender is designed specifically for bending stainless steel tubing, aluminum, copper and tubing of various alloys can be handled successfully provided the combined hardness and elongation characteristics are within the range of Specification MIL-T-6845. In some cases the wall thickness listed in Table 1 can be exceeded when bending aluminum and copper. Experience in using the machine will best determine what ranges can be handled successfully with tubing other than stainless steel.

8. Before bending is started, the tube is clamped into the machine between the form block and form shoe and positioned at the normal starting point which is indicated by a dial on the tube bender proper. By watching the dial, any desired degree of bend can be effected, since the dial indicates accurately all movements of the form block and shoe. To properly hold the tube at the beginning point of the bend a clamp yoke, which must be fitted with the proper size clamp block, is provided. The clamp block has the correct radius to match the radius of the form block which has been selected for the particular diameter of the tube to be bent.

9. The tube bender proper is operated with the ratchet handle included. A large pad on the underside of the housing is provided for clamping between the jaws of a vise which must be 4 inches or larger in order to hold the machine safely. All accessories for use with the tube bending machine proper are quickly installed and removed, making the selection of sizes and actual bending a fast and practical operation.

10. The tube bending machine is not intended for permanent installation. Each part of the complete kit has a special place in the carrying case, thus making the equipment completely portable so that it can be transported from one location to another.

TABLE 1. TUBE SIZES

| Tube diameter (O.D. inches) | Wall thickness (inches) | Bend radii, measured to center-line of tubing |
|--------------------------------|----------------------------|---|
| 1/4 | 0.016 - 0.049 | 9/16 |
| 5/16 | 0.020 - 0.065 | 11/16 |
| 3/8 | 0.028 - 0.083 | 15/16 |
| 1/2 | 0.035 - 0.083 | 1 - 1/4 |
| 5/8 | 0.042 - 0.083 | 1 - 1/2 |
| 3/4 | 0.049 - 0.083 | 1 - 3/4 |

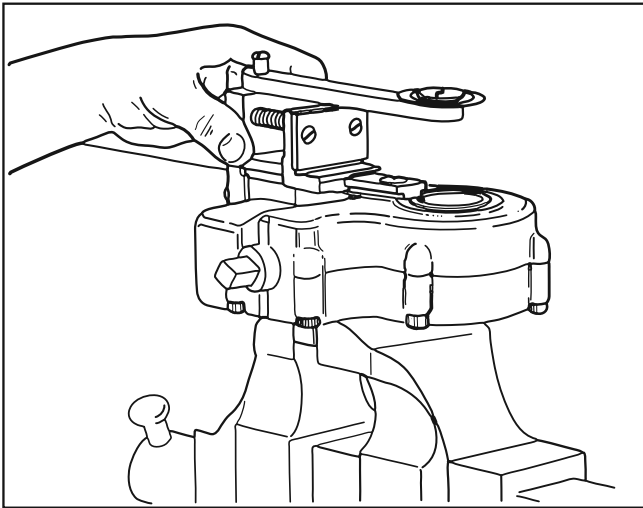

Figure 2. Clamping the Tube Bender Proper in a Vise

11. OPERATION.

12. SETTING UP THE MACHINE. (See Figure 2.)

a. Use a substantial vise with strong, firm-gripping jaws. Open the jaws wide enough to receive the boss on the underside of the housing and clamp the tube bender proper securely between the vise jaws, making certain the jaws are tight enough to prevent any possibility of the machine slipping out during actual bending operations. Considerable force is required on the ratchet handle for bending 3/4 inch stainless steel tubing, having maximum wall thickness, and a weak-jawed vise would not hold the machine.

b. Select the proper size drive shaft to fit the form block of the required size and insert the drive shaft into the tube bender proper with the large splines downward. (See figure 3.) Make certain the drive shaft splines are fully engaged and that the drive shaft is inserted all the way into the tube bender so that the lower journal is in the inner race of the ball bearing. (43, figure 12.)

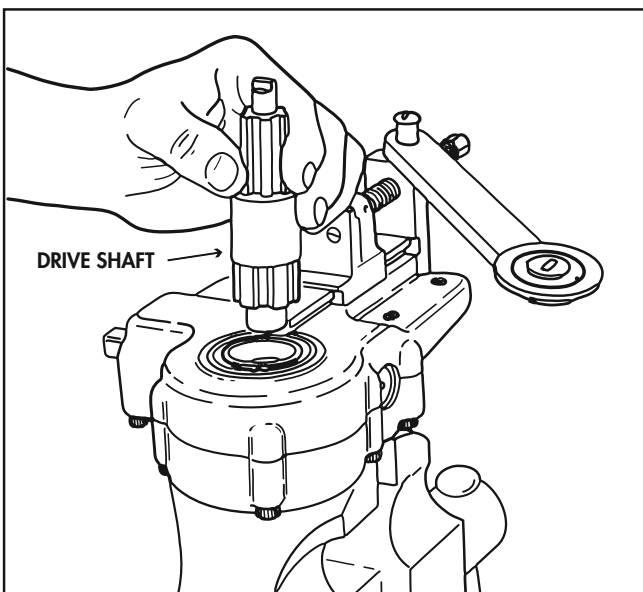

Figure 3. Installing Drive Shaft in Tube Bender Proper

c. Select the proper size form block and install it on the drive shaft. (See figure 4.) Rotate the squared countershaft drive end (37, figure 12) by hand to position the form block with the starting point of the groove parallel with the form shoe, when installed.

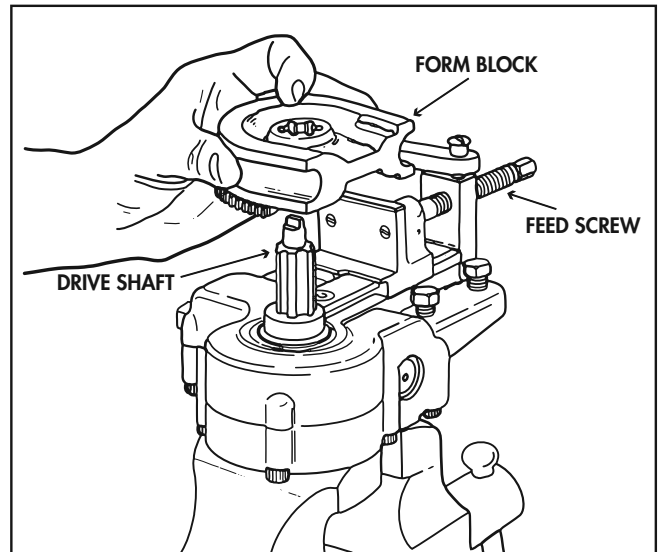

Figure 4. Placing the Form Block on the Drive Shaft Spline

NOTE

If the feed screw is turned in too far, the form shoe slide block will interfere with installation of the form block.

d. Select the proper size clamp block, turn it so that the correct groove will be facing outward and slide the clamp block into the clamp yoke. (See figure 5.)

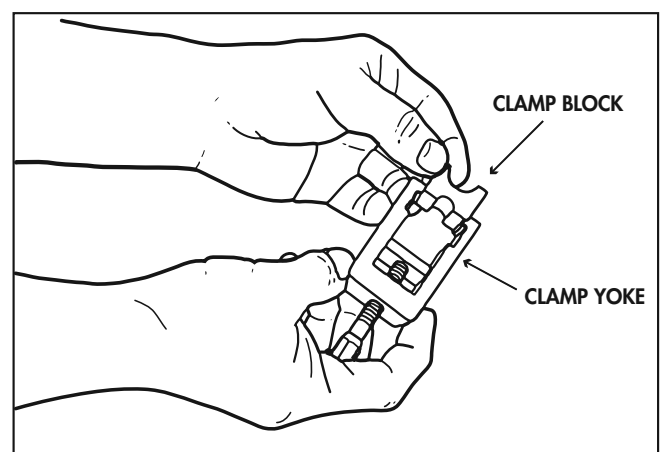

Figure 5. Installing Clamp Block in Clamp Yoke

e. Place the tube to be bent in the groove of the form block, at the location of the desired bend, and clamp it into place with the clamp yoke. (See figure 6.) Make sure the clamp yoke is in proper position

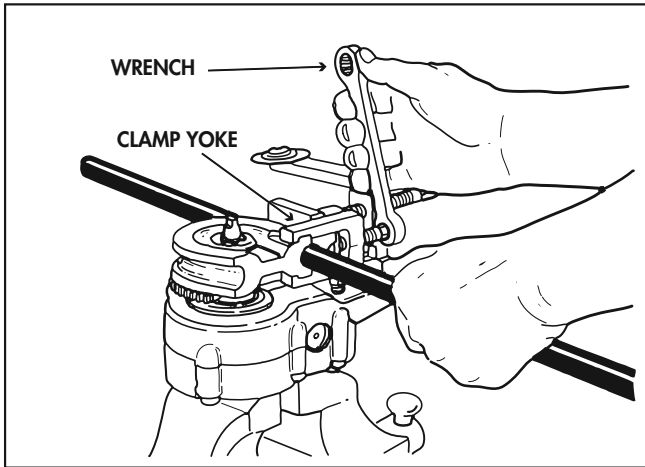

Figure 6. Tightening the Clamp Yoke on the Form Block

on the form block. Tighten the clamp yoke screw with the double-ended wrench provided.

f. Select a form shoe containing the correct size groove for the tube to be bent, and engage the dowels on the rack into the holes on the underside of the form shoe. (See figure 7.) The form shoe can be turned end to end, with respect to the rack, to select the proper size groove in the form shoe.

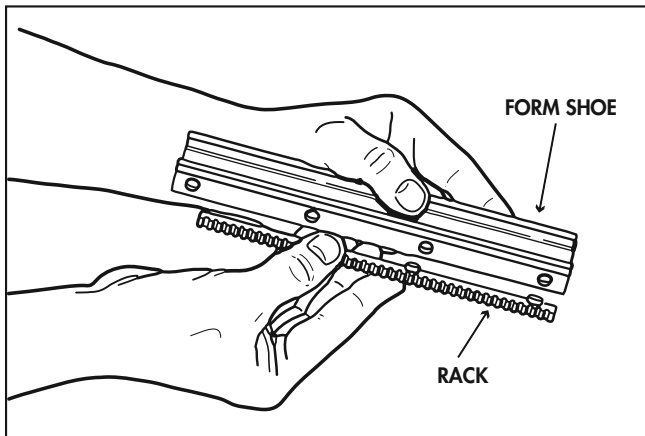

Figure 7. Attaching the Rack to the Form Shoe

g. While holding the rack in engagement with the form shoe, slide the form shoe into place alongside the tube which is clamped into the form block. The end of the form shoe should be inserted far enough to almost touch the clamp yoke. (See figure 8.) If the form shoe slide block is in too far to permit insertion of the form shoe, retract the feed screw until the form shoe can be slipped into place.

h. While holding the form shoe against the tube to be bent, rotate the feed screw until the pressure plate in the form shoe slide block is in light contact with the form shoe. (See figure 9.) This will hold the form shoe in place while making further preparations for making the bend.

NOTE

Do not tighten the feed screw at this time, as it will spring the screw post enough to prevent engagement of the tension yoke.

i. Rotate the bend indicating plate (dial) until the slot at the center of the dial is parallel with the flat key milled on the upper end of the drive shaft. Move the tension yoke into position and press downward until the milled key on the end of the drive shaft passes through the cap slot at the center of the dial. (See figure 10.)

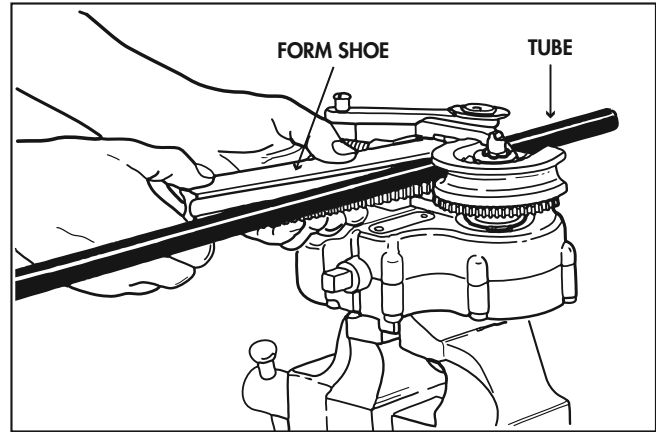

Figure 8. Sliding the Form Shoe and Rack Into Position

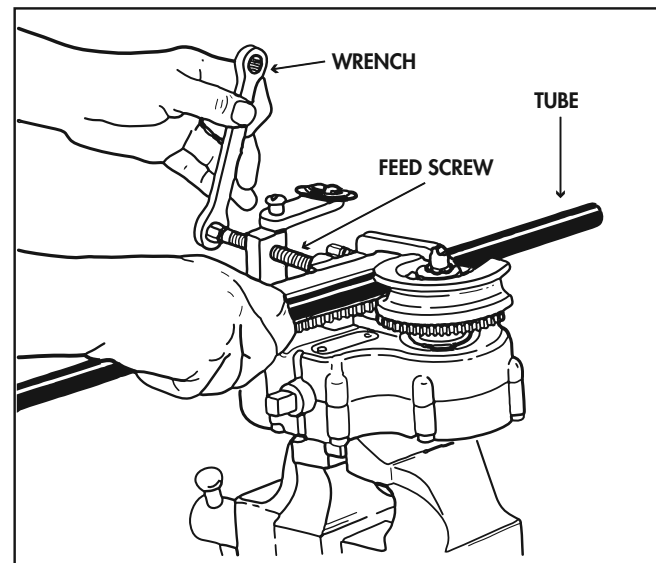

Figure 9. Rotating Feed Screw With Double Ended Wrench

NOTE

If difficulty is experienced in engaging the tension yoke, loosen the feed screw slightly.

j. For original bends in straight tubing, the parts should be positioned so that the dial is set at zero, however, the initial starting point can be positioned at any desired location to accommodate tubes already having partial bends. When the dial is engaged with the milled key on the end of the drive shaft the degree of the bend already in the tube will be indicated.

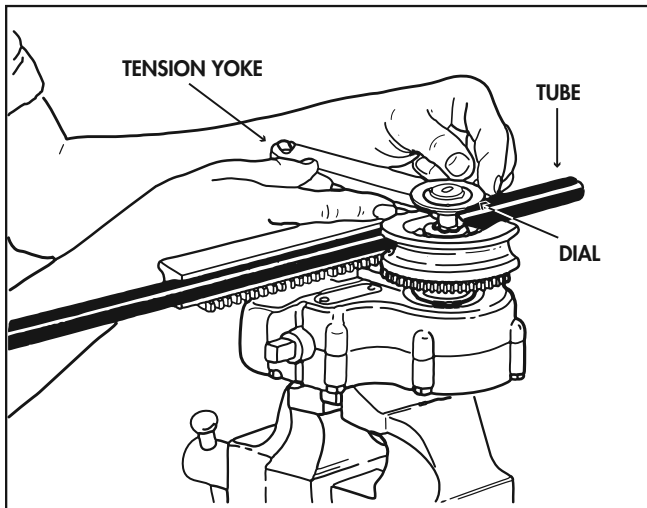

Figure 10. Engaging the Tension Yoke and Dial

k. After engaging the dial, tighten the feed screw securely to force the faces on the form shoe against the faces on the form block. (See figure 9.)



Make sure the teeth on the rack are meshed with the teeth on the sector gear before tightening the feed screw.

13. BENDING PROCEDURE.

a. Engage the ratchet handle with the square end of the shaft which protrudes from the side of the housing. Rotate the shaft in a clockwise direction. (See figure 11.)

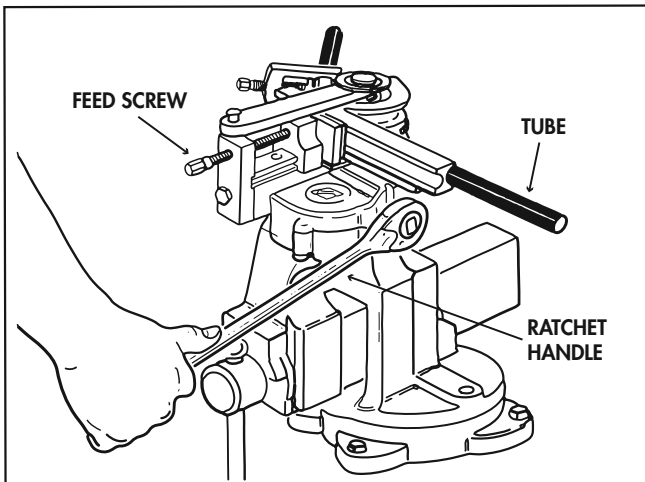

Figure 11. Forming a Bend with Tube Bender Clamped in a Vise

b. While the ratchet handle is being operated, the form block rolling against the form shoe will bend the tube to the same radius as the groove in the form block. Before beginning the bend, determine the angle of bend desired and operate the ratchet handle until the dial indicates the pre-determined degree of bend. When the tubing is released from the tube bender,

there will be a small amount of "spring-back"; the actual amount varying in proportion to the hardness and elongation characteristics of the tubing. This "spring-back" will also increase the diameter of the bend slightly. Experience will best determine the exact amount of "spring-back" and dictate the amount of over-run required in order to anticipate the exact degree of bend acquired after the tubing is released.

NOTE

Lubricants are neither required nor recommended on any of the parts during bending operations.

c. When bending is complete, remove the ratchet handle, loosen the feed screw and lift the tension yoke straight up until free of the drive shaft. Rotate the tension yoke to one side and remove the form shoe from the tube bender. Release the tube from the form block by loosening the screw in the clamp yoke.

NOTE

After finishing with the equipment, pack all parts in the carrying case to prevent misplacement of components.

14. MAINTENANCE.

15. The tube bender and accessories are calculated for stresses well in excess of any stress that will be encountered in actual tube bending operations. As a result, very little maintenance should be required at any time, provided the external components are kept free of dust and grit which would produce excessive wear on the parts.

16. CLEANING.

17. Dust, dirt and other foreign material should not be permitted to collect on the feed screw, pressure plate, form shoe, slide block and other exposed parts of the machine. Foreign material should also be wiped off form blocks, form shoes, rack and sector gears before beginning any bending operation. Remove foreign material with a stream of compressed air, aided by a soft bristle brush if particles are difficult to dislodge. Wipe all parts including the housing occasionally with a clean cloth. If grease and other stubborn accumulations are present on the parts, wet the cloth with naphtha or dry cleaning solvent, Federal Specification P-S-661b.

18. LUBRICATION.

19. All bearings, gears and parts located inside the housing are lubricated during assembly by packing gear teeth with extreme-pressure, low-temperature grease, Specification MIL-G-7118, or equivalent. No lubrication is required except when the tube bender proper is disassembled for repairs, at which time the old grease should be removed by washing in dry cleaning solvent, Federal Specification P-S-661b, and repacking with fresh grease of the above specification, or equivalent.



Ordinary cup grease and similar lubricant

must not be used, since they will not withstand the extreme contact pressures. If grease of the above specification, or an equivalent, is not available, be sure to use an extreme-pressure, low-temperature grease from a reliable commercial source.

20. TROUBLE SHOOTING.

21. Principal troubles that might be encountered, together with their possible causes and remedies, are given in Table II.

TABLE II. TROUBLE SHOOTING

| Trouble | Probable Cause | Remedy |
|--|---|---|
| TUBE WRINKLES ON INNER RADIUS OF BEND | Tubing O. D. is undersize or out of tolerance specified in Table I, and therefore does not properly fit the grooves in the form block and shoe. | Use proper size tubing. |
| | Feed screw not tightened sufficiently to force edges of form block and shoe together. | Tighten feed screw. |
| RIDGES ARE FORMED ON TUBE AT BEND | Incorrect size of form block and shoe being used | Change to correct size of form block and shoe. |
| TUBING MARRED AT BEND | Damaged form block and/or shoe | Replace damaged components. |
| DRIVE SHAFT FAILS TO ROTATE WHEN RATCHET IS OPERATED | Shear pin sheared in drive end permitting it to slip on shaft | Install a new shear pin. (38, figure 12.) |
| | Damaged gears | Disassemble the tube bender proper and replace damaged parts. |
| TUBE BENDER BINDS OR LOCKS | Worn gears | Disassemble the tube bender proper and replace damaged parts. |
| | Damaged ball bearings | Replace ball bearings. |

22. DISASSEMBLY. (See figure 12.)

NOTE

If the tube bender proper is operating normally, it is not necessary to disassemble it at regular calendar overhaul periods. The only time overhaul operations are required is when internal trouble is suspected, at which time the two housing sections should be separated, all parts cleaned and inspected, damaged parts replaced and the housing packed with fresh lubricant.

a. Remove the cap screw (21) and lock washer (22) to free the screw post (20) from the upper half housing (28). Slide the form shoe slide block (19) off the slide block support (24). If removal of the feed screw (18) from the form shoe slide block (19) is required, drive out the spring pins (17) with a long point punch to release the feed screw (18).

b. If the slide block support (24) is worn or damaged, remove the two screws (25) to free the slide block support (24) from the upper half housing (28).

c. Do not remove the name plate (26) unless it is broken, or the data thereon is illegible. If removal is required, remove the two drive screws (27).

d. Remove all socket head screws (29) and lock washers (30) from the lower half housing (44). It may

be necessary to tap along the parting edges of the upper and lower half housings (28 and 44) to separate them. Use the sharp end of a screwdriver blade to pry the housings apart, if necessary, while exercising care to avoid damaging the mating surfaces of the two housing valves.

e. After the upper and lower half housings (28 and 44) are separated, most assemblies can be lifted out of their respective locations. It may be necessary to use a wood dowel as a drift to tap the bearings out of their respective recesses.

f. To remove the spacer (40), drive out the pin (38) with a long point punch. Make certain the counter-shaft drive end (37) is properly supported when driving out the (shear) pin (38).

g. Slide the worm gear (35) off the shaft (41).

h. Further disassembly will consist of separating individual parts that normally would not require removal. The location of each of these parts is shown in figure 12, and removal or installation should be obvious since all parts are exploded out from their proper locations.

23. INSPECTION.

24. The following table provides basic inspection procedures for all parts of the tube bender assembly. These checks are to be considered as basic, however, if other damage not covered in the table is obvious such parts should be replaced.

INSPECTION OF INDIVIDUAL PARTS AND COMPONENTS

(See figure 12 for reference numbers)

| Ref. No. | Nomenclature | Inspection |
|-----------------|------------------------------|---|
| 2 | Bend indicating plate cap | Replace if broken or if slotted hole at center is badly worn. This would cause incorrect readings. |
| 3 | Sleeve bearing | Check for fit on upper end of drive shaft (31). Replace bearing if excessively loose, as this would cause undue strain on certain parts. |
| 4 | Bend indicating plate (dial) | Replace if bent or cracked. |
| 7 | Form block assemblies | Check for damage to form grooves, damaged or worn splines at center and loose sector gear. Loose sector gears can be tightened by installing new pins, but the blocks should be replaced for other conditions. Sector gears having worn or damaged teeth should be replaced. |
| 8 | Clamp block | Replace if chipped or distorted. |
| 10 | Clamp block pressure pad | Replace if bent. |
| 11 | Clamp yoke screw | Replace if threads are worn or damaged. |
| 12 | Clamp yoke | Replace if cracked or distorted. Also check for damaged threads, and if retapping fails to restore threads, replace the yoke. |
| 13 | Form shoe | Check for bends, twists and damaged forming channels. Replace for any of these conditions. |
| 14 | Rack | Check for bends, worn or damaged gear teeth and damaged dowels. Replace for any of these conditions. |
| 15 | Pressure plate | Replace if worn or cracked. |
| 18 | Feed screw | Replace if bent, or if threads are damaged. |
| 19 | Form shoe slide block | Check for distortion and wear in track on underside of block. Replace for either condition. |
| 20 | Screw post | Check for bends and damaged or worn feed screw threads. Replace for either condition. |
| 23,39 and 43 | Ball bearings | Hold the outer race and rotate the inner race to determine if bearings are rough or worn. Rotation should be smooth and free of resistance except for slight pressure produced by the bearing seals. If bearings are loose, rough, or if seals are damaged the bearings should be replaced. |
| 24 | Slide block support | Replace if worn, cracked or bent. |
| 26 | Name plate | Replace only if damaged, or if data on plate is not clearly visible. |
| 28 | Upper half housing | Check for cracks, stripped threads and distortion. Distortion can be detected by placing the parting surface of the housing against a surface plate. Contact should be made throughout the entire parting surface. |
| 31 | Drive shaft | Check for excessive wear on splines at both ends, and wear on milled key at the top end. Replace for either condition. |
| 32 | Drive gear | Check for damaged or worn splines and rough or worn teeth. Replace for either condition. |

INSPECTION OF INDIVIDUAL PARTS AND COMPONENTS (Cont)

| Ref. No. | Nomenclature | Inspection |
|----------|------------------------|--|
| 33 | Sleeve bearings | Check for wear by trying the bearing on its respective shaft journal. If more than 0.002 inch clearance exists, replace the bearing. |
| 35 | Worm | Check for cracks and worn thread. Replace for either condition. |
| 36 | Key | Check for wear caused by keyway "biting" into the sides of the key. Replace if worn or broken. |
| 37 | Countershaft drive end | Replace if cracked or if square shank is worn. |
| 38 | Pin | Check for compression marks and indentations. Replace if damaged. |
| 40 | Spacer | Replace if broken, worn or scored. |
| 41 | Shaft | Check for bends, cracks and scored bearing journal. Replace for any of these conditions. |
| 42 | Ratchet handle | Check for proper operation of ratchet mechanism. |
| 44 | Lower half housing | Check for cracks and distortion. Distortion can be detected by placing the parting surface on a surface plate. Contact should be made throughout the surface with the plate. |
| All | Screws and nuts | Check for damaged threads and other visible damage. Replace all damaged parts. |
| All | Pins | Replace if damaged. |

25. REPAIR OR REPLACEMENT.

26. Repairs consist essentially of replacing worn or damaged parts. Refer to instructions in the inspection table for checks which determine when parts should be replaced.

27. REASSEMBLY. (See figure 12.)

a. Press the ball bearing (43) into the recess of the lower half housing (44).

b. Slide the spacer (40) on the small diameter end of the shaft (41). Insert key (36) into the keyway. Press the ball bearing (39) into place against the spacer. Slide the countershaft end (37) on the shaft (41), rotate the end until holes are aligned, and press the pin (38) into place. Swell each end of the pin (38) slightly with a center punch to prevent it from becoming loose during service.

c. Press the worm (35) on the shaft (41) until the end of the worm contacts the spacer (40). Place the spacer (34) and sleeve bearing (33) on the bearing journal of the shaft (41).

NOTE

Sleeve bearings should be soaked in hot oil before inserting shaft journals.

d. Place the shaft (41), with parts attached, into the lower half housing (44). If the ball bearing (39) and sleeve bearing (33) fail to fit into their respective recesses, recheck for proper installation of parts on the shaft (41).

e. Place the drive gear (32) into position on top of the ball bearing (43). Insert the lower end of one of the drive shafts (31) through the drive gear (32) and into the inner race of the ball bearing (43). The drive shaft (31) can be lifted out after reassembly, but when placed in position during reassembly it will hold the drive gear (32) in proper position, thus facilitating installation of the upper half housing (28).

f. Pack grease into all gear teeth as outlined in paragraph 19.

g. Press the ball bearing (23) into the recess of the upper half housing (28) and carefully place the upper half housing (28) on the lower half housing (44). If all parts have been properly assembled, the housing will fit together without excessive resistance. It may be necessary to tap the top housing lightly with a soft faced mallet in order to assist in settling all bearings into their recesses.

h. Install screws (29) and lock washers (30), and tighten securely.

i. Install the slide block support (24) on the upper half housing (28) with screws (25). Tighten screws securely.

j. Install the pressure plate (15) on the form shoe slide block (19) with screws (16); if the plate was removed during disassembly. Slide the form shoe slide block (19) on the slide block support (24).

k. Thread the feed screw (18) into the screw post (20), engage the end of the feed screw (18) into the form shoe slide block (19), and drive the two pins (17) into their holes. Attach the screw post (20) to the upper half housing (28) with the cap screw (21) and lock washer (22).

l. If the tension yoke (5) was disassembled for replacement of parts, place the bend indicating (dial) plate (4) on the sleeve bearing (3) and press the sleeve bearing into the hole at the end of the tension yoke (5), leaving just enough clearance between the flange of the sleeve bearing (3) and plate (4) to permit the dial to rotate without interference. Attach the cap (2) with the two screws (1). Attach the tension yoke (5) to the screw post (20) with the screw (6).

m. If the name plate (26) was removed, install a new name plate with the two drive screws (27).

n. If a new clamp block pressure pad (10) was required, attach it to the end of the clamp yoke screw (11) with the screw (9). Leave the screw (9) loose enough to permit the screw (11) to rotate.

o. If any of the sector gears were removed from their respective form block assemblies (7), attach them by installing new pins. Alignment of splines in the sector gear and form block can be assured if the correct size drive shaft (31) is inserted temporarily through the splines of both parts before pressing the pins into position.

28. TESTING AFTER OVERHAUL.

a. After reassembly has been completed, perform bending operations on several sizes and types of tubing to make sure that the machine is operating properly. If any trouble is encountered, it must be remedied and the machine rechecked before placing it in storage or putting it into operation.

b. Bends performed after overhaul must be unmarred, free of kinks, wrinkles and surface imperfections. All bends made in like material must be uniform, and the reduction in cross-sectional diameter (flatness across throat) at any point in the bend must not exceed five percent of the original diameter of the tube.

c. If the tube bender passes these tests satisfactorily, it is ready to be stored or placed into service.

SECTION II REPLACEMENT PARTS LIST

| Figure and Index No. | Imperial Part No. | Part Description | Qty. | Figure and Index No. | Imperial Part No. | Part Description | Qty. |
|----------------------|-------------------|-----------------------------------|------|----------------------|-------------------|--|------|
| 12- | | | | 12- | | | |
| -1 | 74597 | SCREW, No. 2 - 56x1/2"..... | 2 | -18 | 74562 | SCREW | 2 |
| -2 | 74559 | CAP | 1 | -19 | 74563 | BLOCK | 1 |
| -3 | 74560 | BUSHING | 1 | -20 | 74556 | POST..... | 1 |
| -4 | 74558 | PLATE | 1 | -21 | 74594 | SCREW, 1/2 - 13x1-1/4" | 1 |
| -5 | 74557 | BAR | 1 | -22 | 74595 | LOCKWASHER | 1 |
| -6 | 74596 | SCREW, 1/4-20x5/16" | 1 | -23 | 74543 | BALL BEARING | 1 |
| -7 | 74569 | BLOCK GEAR ASSY. (1/4") | 1 | -24 | 74561 | SUPPORT | 1 |
| -7 | 74572 | BLOCK GEAR ASSY. (5/16") | 1 | -25 | 74598 | SCREW, 3/8 - 16x3/4" | 2 |
| -7 | 74575 | BLOCK GEAR ASSY. (3/8") | 1 | -26 | 74532 | NAMEPLATE | 1 |
| -7 | 74578 | BLOCK GEAR ASSY. (1/2") | 1 | -27 | 74601 | DRIVE SCREW, No. 4 x 5/16" ... | 2 |
| -7 | 74581 | BLOCK GEAR ASSY. (5/8") | 1 | -28 | 74541 | HOUSING UPPER HALF | 1 |
| -7 | 74584 | BLOCK GEAR ASSY. (3/4") | 1 | -29 | 61252 | SOCKET HEAD SCREW, 1/4 - 20x1-1/4"..... | 8 |
| -8 | 74587 | BLOCK (1/4 & 5/16")..... | 1 | -30 | 28843 | LOCKWASHER | 8 |
| -8 | 74588 | BLOCK (3/8 & 1/2") | 1 | -31 | 74554 | SHAFT (1/4") | 1 |
| -8 | 74589 | BLOCK (5/8 & 3/4") | 1 | -31 | 74555 | SHAFT (5/16 - 3/4")..... | 1 |
| -9 | 74604 | SCREW, No. 6 - 32x1/2" | 1 | -32 | 74553 | GEAR | 1 |
| -10 | 74593 | PAD | 1 | -33 | 74550 | BUSHING | 1 |
| -11 | 74592 | SCREW | 1 | -34 | 74549 | SPACER | 1 |
| -12 | 74591 | YOKE | 1 | -35 | 74546 | GEAR | 1 |
| -13 | 74566 | FORM SHOE (1/4 & 5/16")... .. | 1 | -36 | 74548 | KEY | 1 |
| -13 | 74567 | FORM SHOE (3/8 & 1/2") | 1 | -37 | 74552 | COUNTER SHAFT | 1 |
| -13 | 74568 | FORM SHOE (5/8 & 3/4") | 1 | -38 | 68089 | PIN | 1 |
| -14 | 74565 | RACK | 1 | -39 | 74545 | BALL BEARING | 1 |
| -15 | 74564 | PRESSURE PLATE | 1 | -40 | 74551 | SPACER | 1 |
| -16 | 74600 | SCREW, No. 8 - 32x3/8" | 2 | -41 | 74547 | SHAFT | 1 |
| -17 | 74599 | DRIVE PIN | 2 | -42 | 74608 | RATCHET WRENCH | 1 |
| | | | | -43 | 74544 | BALL BEARING | 1 |
| | | | | -44 | 74542 | HOUSING LOWER HALF | 1 |
| | | | | -45 | 74609 | WRENCH | 1 |
| | | | | -46 | 74603 | CARRYING CASE ASSY | 1 |
| | | | | -47 | 79321-01 | SOCKET WRENCH | |

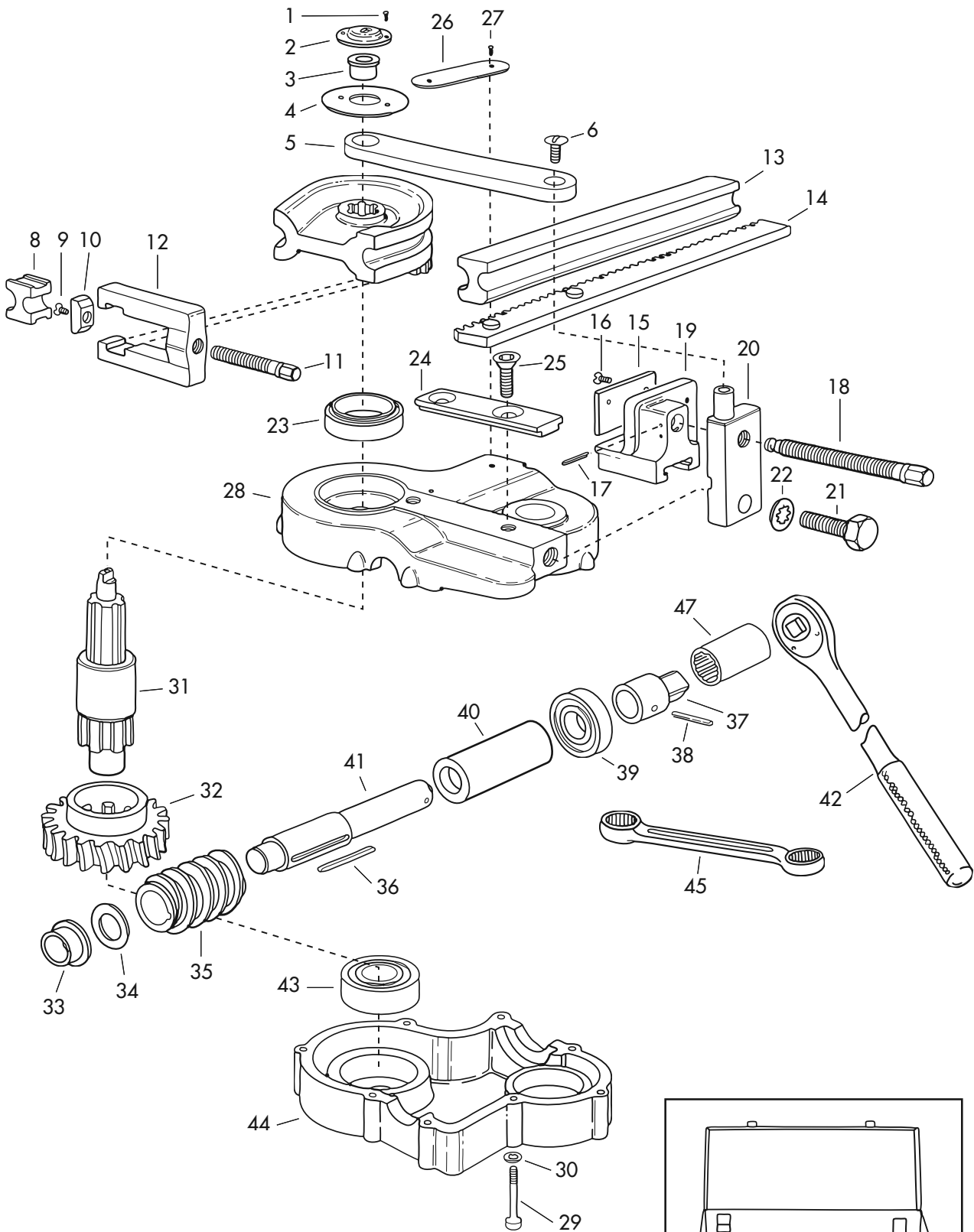
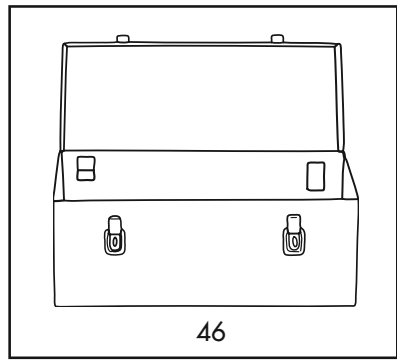

Figure 12. Tube Bender Assembly





30333 Emerald Valley Parkway • Glenwillow, Ohio 44139 USA
www.imperial-tools.com • info@stridetool.com